

LA CELIA  
 Iluminacion: juanjo Llorens  
 PLANO ESCENARIO 1\_4  
 24\_10\_15 V Convencional

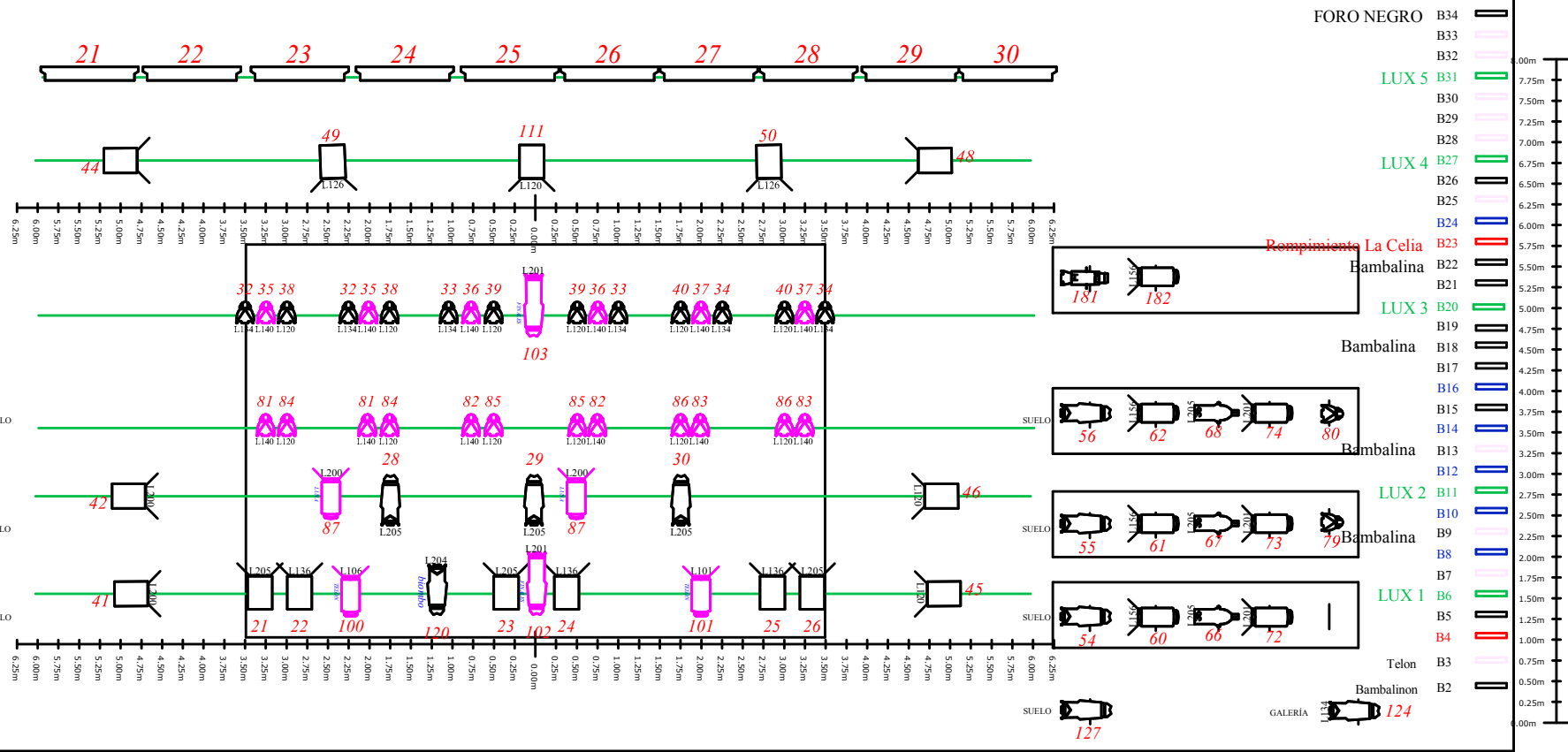

109



110



125



125



93

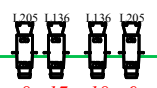

8 17 18 9



94

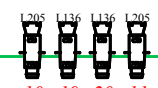

10 19 20 11



95



104



88

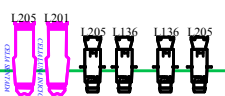

96 97 2 13 14 3

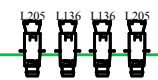

4 15 16 5



99



98



90

125



125



125



114



125

LA CELIA  
 Iluminacion: juanjo Llorens  
 PLANO SALA 2\_4  
 24\_10\_15 V Convencional

LA CELIA

Iluminacion: juanjo Llorens

PLANO ESCENARIO 4\_4

24\_10\_15 V Convencional

## ELEMENTOS DE LUZ DE LA CELIA

CANAL 131 Mesa de camerinos con bombillas 

CANAL 223 Carra luna con bombillas 

CANALES 161 - 162 - 163 - 164 DE LAS BOMBILLAS DE LOS ROMPIMIENTOS ( 4 CANALES ROMPIMIENTO 1)    

CANALES 157 - 158 - 159 - 160 DE LAS BOMBILLAS DE LOS ROMPIMIENTOS ( 4 CANALES ROMPIMIENTO 2 MARCO)    

CANALES 143 - 144 - 145 - 146 - 147 - 148 - 149 - 150 - 151 - 152 - 153 - 154 - 155 - 156 DE LAS BOMBILLAS DE LOS ROMPIMIENTOS ( 14 CANALES ROMPIMIENTO 2 VERTICALES)









## LA CELIA

Director: Emilio Saggi

Escenografía: Daniel Bianco

Iluminación: juanjo Llorens

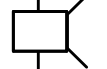
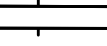
	10	ETC 15/30
	14	ETC 25/50
	15	ETC 19 grados
	08	ETC 26 grados
	06	STRAND LIGHT 36 grados
	34	ETC SOUR FOUR LENTE 5
	18	PC RAMA
	15	ARENA TEATRO FRESNEL
	10	BARRAS DE LEDS RGB

## REGULACION Y CONTROL

130 Canales de dimmer





Mesa de control MA Series 1

## COLORES

Lee 120, Lee 134, Lee 136, Lee 156, Lee 200, Lee 201, Lee 205

## ESTRUCTURAS Y SOPORTES

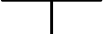
### CALLES DE LUZ

	3,40 aprox
	2.55 aprox
	1,70 aprox
	0.85 aprox
	0.00 aprox

LA CELIA

Iluminación: juanjo Llorens

PLANO LEYENDA 3\_4